

MODEL 2310 AL

MCS-11 REMOTE ENCODER



FIAL INCORPORATED

710 Center Street
Oregon City, OR 97045
503.607.1940
WWW.FIAL.COM

DOCUMENT NUMBER FC2310_AL-040506
COPYRIGHT © 2004 BY FIAL INCORPORATED

NOTICE OF FCC COMPLIANCE

NOTE

This equipment has been tested and found to comply with the limits for a Class A digital device pursuant to Part 15 of FCC Rules. These limits are designed to provide reasonable protection against harmful interference when this equipment is operated in a commercial environment. This equipment generates, uses, and can radiate radio frequency energy and, if not installed and used in accordance with the instruction manual, may cause harmful interference to radio communication. Operation of this equipment in a residential area is likely to cause harmful interference, in which case the user will be required to correct the interference at his/her own expense.

Table OF CONTENTS

BRIEF DESCRIPTION.....1
DETAILED DESCRIPTION.....3
INSTALLATION.....7
 STATION GROUND JUMPER (STA. GND) CAUTION.....7
PROGRAMMING.....13
REAL TIME MONITORING22
MCS-11 REMOTE ENCODER MODEL 2310 AL SPECIFICATIONS25
MCS-11 REMOTE ENCODER CONNECTOR PIN ASSIGNMENTS.....27
APPENDIX A -- CONSIDERATIONS FOR TSM-2500/8000 CONFIGURATION31

FIGURES

FIGURE 1. MODEL 2310 AL FRONT PANEL2
FIGURE 2. MODEL 2310 AL REAR PANEL.....2
FIGURE 3. POSITIVE GROUND SYSTEM7
FIGURE 4. NEGATIVE GROUND SYSTEM.....7
FIGURE 5. BATTERY POLARITY SELECT FOR OPTOISOLATORS.....8
FIGURE 6. DCE VERSUS DTE SELECTOR SWITCH9
FIGURE 7. EXAMPLE OF HIGH-SPEED SYNCHRONOUS TO LOW-SPEED ASYNCHRONOUS SPUR10
FIGURE 8. EXAMPLE OF HIGH-SPEED ASYNCHRONOUS HOP11
FIGURE 9. GENERAL PAGE (DEFAULT).....13
FIGURE 10. BRIDGE POLLS SELECTION14
FIGURE 11. RSS OR RDS PAGE17
FIGURE 12. RCDI PAGE.....19
FIGURE 13. RAS PAGE.....20
FIGURE 14. RDS PAGE IN MONITOR MODE.....22
FIGURE 15. RCDI PAGE IN MONITOR MODE23
FIGURE 16. RAS PAGE IN MONITOR MODE.....24

TABLES

TABLE 1. MULTIPLIERS FOR MCS-11 MASTER CONFIGURATION4

TABLE 2. ANALOG INPUT ATTENUATION VERSUS FREQUENCY6

TABLE 3. ADDITIONAL TIMES FOR ASYNC HOPS12

TABLE 4. MCS-11 RS-422 PIN ASSIGNMENT (DB-15F)27

TABLE 5. MCS-11 RS-232 PIN ASSIGNMENT (DB-15F)27

TABLE 6. MCS-11 RS-232 PIN ASSIGNMENT (DB-15F)27

TABLE 7. RELAY OUTPUT CONNECTOR PIN ASSIGNMENTS28

TABLE 8. ALARM INPUT CONNECTOR PIN ASSIGNMENTS29

TABLE 9. ANALOG INPUT CONNECTOR PIN ASSIGNMENTS30

TABLE 10. CRAFT INTERFACE PORT (RS-232) PIN ASSIGNMENTS30

BRIEF DESCRIPTION

The Model 2310 AL is a remote alarm encoder for MCS-11 monitored systems. It can monitor 32 alarm points, control 16 on/off points, and (optionally) read up to 16 analog voltages. A Windows program is used to configure the unit, via an RS-232 craft port interface.

The unit has two MCS-11 ports for remote monitoring. Both ports operate in DTE mode, while one of the ports may be switched to either DTE or DCE mode operation. The 2310 AL always listens to polls coming in from both MCS-11 ports and can be configured to answer polls in one of two ways. If the 2310 AL receives a poll for its address, it can either send the answer out both ports, or send it only out the same port on which its poll was received.

Both ports may be set to operate at either RS-422 or RS-232 interface levels. Each port on the 2310 AL may be configured for either synchronous or asynchronous clocking. This feature allows MCS-11 network traffic to be carried via asynchronous RS-422 or RS-232 signaling. This may be useful where synchronous MCS-11 channels are not available between radio hops.

The 2310 AL may also be configured to bridge MCS-11 packets, so that the unit acts like a two port bridge for MCS-11 traffic. The bridging can be configured to include all addresses in the 128 station MCS-11 address range (typical), or to selectively specify the addresses to bridge, blocking all others (useful with slow async spurs extending beyond the 2310 AL).

Existing configuration information can be uploaded from a 2310 AL via the craft port interface and a Windows based user program. The 2310 AL can also monitor real-time alarm events with this program, via the craft port, to aid a field technician in some troubleshooting situations.

MODEL 2310 AL MCS-11 REMOTE ENCODER

The Model 2310 AL MCS-11 Remote Encoder includes front panel LED indicators for power, unit fail, summary alarm and MCS-11 data and clock signals. It also includes 32 front panel alarm point indicator LEDs. These LEDs display the current status of the unit's associated RSS or RDS alarm points. The 32 alarm LEDs are arranged in 2 rows of 16 LEDs each.



Figure 1. Model 2310 AL Front Panel



Figure 2. Model 2310 AL Rear Panel

Pressing the LAMP TEST button on the 2310 AL turns on all front panel LEDs, verifying proper operation of the lamps. There is also an additional function for this button. Pressing and **holding** the LAMP TEST button for over three seconds changes the front panel alarm LED display to indicate the current state of the internal control relays. Control relays that are currently asserted (ON) will have their corresponding front panel LED on. There are only 16 control relays, so only the first 16 (top row) LEDs are used to indicate control relay states. Releasing the LAMP TEST button returns the alarm LEDs to their normal function.

The Model 2310 AL may be powered by 24 or 48 volt station battery, without any switch or jumper changes necessary. It mounts in a 19-inch rack, and is 1U high.

DETAILED DESCRIPTION

ALARM INPUTS: The 32 alarm inputs are optically isolated. Alarm inputs can be asserted by connecting the input to station ground or by removing ground from the input. Alarm inputs can be delayed before asserting an alarm. The external switching device must handle a current of 2 milliamperes. The alarm inputs are scanned every 200 milliseconds. The 32 points are addressable as a set to the Remote Station Scanner (RSS) or any one of the MCS-11 Remote Detail Scanners (RDSs). When the alarm points are placed in an RDS, an RSS summary point may be configured to assert when any of the RDS alarm points are asserted. This summary point may be placed in any one of the 32 RSS point positions. A normally open relay output may be configured to close whenever this summary point is asserted. The alarm input connector is a female 50-pin CHAMP on the rear panel.

RDS points in alarm can only affect a summary bit if the RDS is summarized to an RSS point (recommended). If you do not map the RDS to a summary point, then RDS alarms in the 2310 AL will not get polled by the MCS-11 monitoring system unless the RDS is in Rapid Poll or Cyclic Poll. If the alarm points are mapped to an RDS, and the summary point for the RSS is set to NONE, then the 2310 AL will not answer RSS polls. This is useful in cases where an RSS already exists at a site, and you just want to add an RDS using the 2310 AL Encoder. In this case, the summary relay contacts can be used to set a summary bit in the existing RSS (hard-wired from the 2310 AL to the radio). Note that the summary relay will be closed when an alarm point is set. It will not be closed if status points are set.

ALARM POINT VS STATUS POINT: Each of the 32 inputs may be configured to be an alarm point or a status point. Once asserted, an alarm point is latched until read (polled). Status points are not latched -- the state of the point in the scanner changes in real-time with the state of the input pin. Also, if the 32 points are mapped to an RDS scanner, then a summary point may be set whenever one or more alarm points are asserted. Summary points are never affected by the state of a status point.

DELAYED ACTIVATION: Each of the 32 inputs may have a delay associated with it. This is useful when you want to ignore short, intermittent events. The delay may be set from one second up to about 18 hours. For example, if an input has a 10 second delay set, then the point must be continuously asserted (uninterrupted) at the input pin for a minimum of 10 seconds before the alarm point is set in the scanner.

CONTROL OUTPUTS: The 16 control outputs are derived from relays with form-C contacts (normally open, common, and normally closed contacts). The form-C contacts allow the power-off default to be wired as normally off or normally on. The 16 control points are addressable as a set to any one of the 6 MCS-11 Remote Control Decoder Interfaces (RCDIs). The relay output connector is a female 50-pin CHAMP mounted on the rear panel. The contacts are rated for 1 Amp up to 48 volts DC, 0.6 Amps at 110 volts DC, and 0.6 Amps at 125 volts AC.

The default mode of operation for the control point is ON/OFF. An MCS-11 ON command will

close the relay, and an MCS-11 OFF command will open the relay. The configuration program also allows you to make any of the outputs act in a momentary fashion. If momentary is selected, then the relay is operated for 200 milliseconds for each MCS-11 ON command. MCS-11 OFF commands are ignored for points selected as momentary. You may set the amount of time that a momentary control point (status) is reported as ON using the configuration program.

ANALOG INPUTS: An optional analog input card is available. This card provides 16 voltage-measuring inputs that can be mapped as a set to any one of the RAS scanners. Each input can be set to any one of the ten input ranges in Table 1 below. MCS-11 Remote Analog Scanners (RASs) can contain up to 24 values, and each value can range from 000 to 999. An input voltage equal to the maximum of the range selected will cause the analog scanner value to be set to 999.

Table 1 below lists these values to the precision required. The values in the right column of the table represent the multiplier constant to be used in configuring an MCS-11 master, such as the NGM, TSM-8000, TSM-2500, TSM-3500, DCP-1500, etc. The MCS-11 master will multiply each RAS value by the multiplier you set in order to convert the value to the proper range of counts (the typical units setting is 'voltage'). You will need to enter the proper multiplier for each analog point into the master so that it can display the counts from the 2310 AL properly. Note that for negative input ranges, the multiplier is a **negative** number.

Input range	Multiplier to scale MCS-11 zero to 999 range to volts
0 to +7.5 volts	0.0075075
0 to +15 volts	0.015015
0 to + 30 volts	0.03003
0 to +60 volts	0.06006
0 to +120 volts	0.12012
0 to -7.5 volts	-0.0075075
0 to -15 volts	-0.015015
0 to -30 volts	-0.03003
0 to -60 volts	-0.06006
0 to -120 volts	-0.12012

Table 1. MULTIPLIERS FOR MCS-11 MASTER CONFIGURATION

The analog inputs are generally measured relative to a common ground. However, pairs of inputs may be set to differential input mode. In differential mode, the measurement is made between the two inputs of the pair, rather than between an input and ground. If input **1** is set to differential mode, then input **9** automatically becomes the other input of the pair. In this case, point 1 in the RAS will hold the differential value, but point 9 will always have a 000 value. If input **2** is set to differential mode, then input **10** becomes the other input of the pair, and so on. The configuration

program allows you to choose single-ended vs. differential mode for each pair of points.

The last point in the RAS (point 24) is used to indicate failure of the analog input subsystem.

A 000 in point 24 indicates normal operation. A 999 in point 24 indicates that the analog input card is not responding to requests from the 2310 AL main processor. The master should map point 24 as an 'analog input fail' alarm point when its value is above zero.

The resistance for each analog input is 52,000 Ohms between the input and ground. Other values are available up to 600,000 Ohms (please consult the factory at time of order).

Each analog input is RC lowpass filtered in order to reject higher frequencies. The time constant is approximately 0.05 seconds. The attenuation versus frequency is as follows:

Frequency	Attenuation
DC (0 Hertz)	0x
5 Hz	1.6x
10 Hz	2.8x
20 Hz	4.1x
60 Hz	14.5x
120 Hz	29.2x
240 Hz	58.3x
1000 Hz	175x

Table 2. ANALOG INPUT ATTENUATION VERSUS FREQUENCY

Shielded wire is recommended for connecting distant measuring points to the input connector, and shielded pair cable is recommended for connecting differential inputs to the input connector.

MCS-11 COMMUNICATIONS PORTS: The 2310 AL MCS-11 Remote Encoder has two MCS-11 communications ports available at two DB-15 female connectors on the rear of the unit. The ports are labeled MCS-11 Port 1 and MCS-11 Port 2.

Each MCS-11 port can be configured for either RS-422 or RS-232 interface levels, and for either synchronous or asynchronous modes of operation. Synchronous mode uses separate signals for transmit data, receive data, transmit clock, and receive clock. Asynchronous mode only uses the transmit data and receive data signals, it does not use separate clock signals.

In synchronous mode, Port 1 is strictly a DTE port. This means it accepts transmit and receive clocks from another unit. Port 2 can be set to either DTE (accepts clock) or DCE (generates clock) mode. DCE mode is only allowed for synchronous RS-422. The RS-232 interface is always DTE.

In asynchronous mode, both Port 1 and Port 2 are considered DTE ports. Either port may be set to RS-422 or RS-232 interface levels. For asynchronous RS-422 mode, only transmit data and receive data signals are used (1 pair of wires per signal). In asynchronous RS-232 mode, only transmit data, receive data, and ground are used (1 wire per signal).

The DTE vs. DCE selection is made via the configuration program **and additionally, an internal slide switch**. The cover must be removed to gain access to this switch. The configuration program also sets the clock rate for DCE operation.

The unit always listens for polls on both of the ports and when polled, will either answer out the receiving port only, or out both ports, as configured by the user. The unit can be configured to bridge ALL, or a selected set, of MCS-11 polls and answers between the two ports. For all addresses specified for bridging, all polls and answers received at either MCS-11 port are re-transmitted out of the other MCS-11 port.

INSTALLATION

Install this unit in 24 or 48 volt positive ground or negative ground stations. The factory default is positive ground operation. Power is connected to a 2-terminal barrier strip at the rear of the unit. Mounting ears are supplied for flush or projection mounting in a 19-inch rack.

There is an external chassis ground wire (jumper) that must be connected to the station ground terminal at the power input connector. For positive ground systems (factory default), the jumper should connect between the chassis (labeled Sta. Gnd) and the positive power input terminal. For negative ground systems, the jumper should connect between the chassis (labeled Sta. Gnd.) and the negative power input terminal. This jumper is required for proper operation - it insures that the unit's electrical (chassis) ground is connected to the station ground.

CAUTION: If connected incorrectly, there will be a short across the station battery!

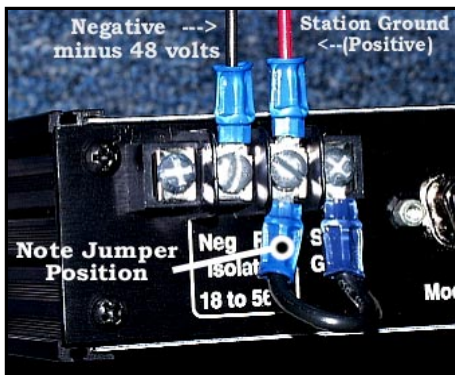

Figure 3. POSITIVE GROUND SYSTEM

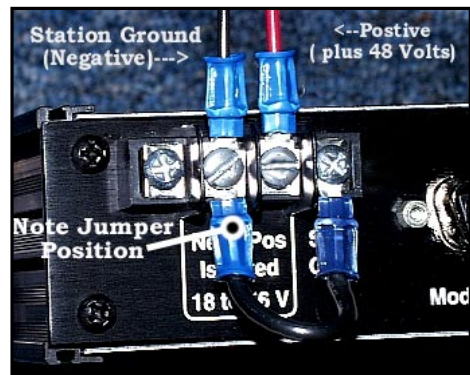

Figure 4. NEGATIVE GROUND SYSTEM

STATION GROUND JUMPER (STA. GND) CAUTION

Some telecom sites require the station battery to be grounded at only one place near the battery bank. If your installation requires an isolated station battery input, you must remove the provided STATION GROUND jumper from the POSITIVE terminal of the power input terminal block on the rear of the unit and provide an alternate connection from this STA. GND terminal to station ground. The best way of providing a proper ground to the unit is to lengthen the jumper connected to STA. GND and securely connect it to the rack ground. Use a longer wire and a crimp/splice connector if necessary. Leave the jumper connected to the STA. GND terminal (terminal block mounting screw - right side). Do not loosen or remove the mounting screw securing the STA. GND jumper to the terminal block, since it is secured with a washer and nut inside the unit.

Do not attempt to operate the equipment without a station ground (STA. GND) connection as electrical damage may occur. The unit's rack mounting screws alone will not provide a reliable rack ground.

There is an internal jumper (see Figure 5) which selects the negative or positive lead of the battery input to power the alarm input optoisolators. For positive ground systems (factory default) the jumper should be in the - **Station Battery** position. This selects the proper polarity voltage input to power the optoisolators. For negative ground systems, the jumper must be in the + **Station Battery** position. If this jumper is in the wrong position, an alarm input will not be asserted when the input is connected to station ground.

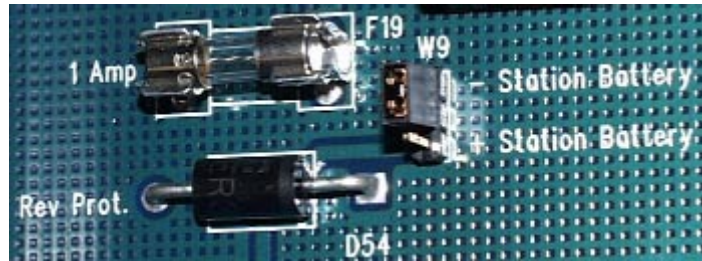

Figure 5. BATTERY POLARITY SELECT FOR OPTOISOLATORS

ALARM INPUTS: You will need a 50-pin male ribbon connector (Amp CHAMP type) for the 32 inputs. It is best to order a pre-assembled cable assembly from a company such as Grayhill. One easy option is to use a cable with a 50-pin connector at one end and a 66 block (punch-down block) at the other end. The punch down block can be mounted on the wall, and all the station alarms brought to that block. The pin assignments for the I/O connectors are detailed at the end of this document.

CAUTION: The alarm input connector pin assignments do **NOT** follow typical Telco pin pairing. There are not enough pins to allow each of the 32 alarm points to have a separately paired ground wire. Follow the pin assignments for the connector detailed at the end of this document (Table 8).

RELAY OUTPUTS: You will need a 50-pin male ribbon connector for the 16 form-C relay outputs (Amp CHAMP type) for the outputs. It is best to order a pre-assembled cable assembly from a company such as Grayhill. One easy option is to use a cable with a 50-pin connector at one end and a 66 block (punch-down block) at the other end. The punch down block can be mounted on the wall, and all the outputs can be connected at that point.

CAUTION: The relay output connector pin assignments do **NOT** follow typical Telco pin pairing. There are not enough pins to allow each of the Normally Open & Normally Closed contacts of the 16 control relays to have a separately paired ground wire. Follow the pin assignments for the connector detailed at the end of this document (Table 7).

ANALOG INPUTS: A single DB25 female connector is used for the analog inputs. Its pin assignments are detailed in Table 9. These inputs will not be functional unless the optional analog-

input board is installed in the unit. The connector has separate pins for station ground and analog ground. These are connected together at the 'common' measurement point on the analog board.

Single ended measurements may be connected between an analog input pin and either station ground or analog ground. For the most accurate measurements, a pair of wires should run from the device being measured to the model 2310 AL, with the 'ground' wire connected to an analog ground pin and the active wire connected to the analog input pin. A shielded wire is recommended for electrically noisy environments, and a shielded pair is recommended for differential input measurements.

The analog inputs are low pass filtered. There is no attenuation for frequencies below 1 Hertz. A 60 Hertz signal is attenuated 14.5 times relative to DC. See Table 2 on page 6 for attenuation data for other frequencies.

Configuring the 2310 AL (with either the craft port interface or Windows programs) to report MCS-11 analog scanner points without having installed an analog-input board is an error condition. This error causes the front panel Unit Fail LED to blink three times, pause, then repeat.

MCS-11 PORTS: There are two MCS-11 ports on the back of the unit. You may select RS-422 or RS-232 operation for each port with the configuration software. For RS-422 operation, both MCS-11 ports can be operated as DTE (accepting clock from other units). In addition, MCS-11 Port #2 can be changed to DCE (providing clock to other units). If DCE operation is selected in the configuration program, the unit's cover must also be removed and an internal slide switch (**S1**) operated. This switch setting **MUST** match the setting downloaded from the configuration program. The configuration program is used to set the DTE / DCE mode and the clock rate for the DCE port.

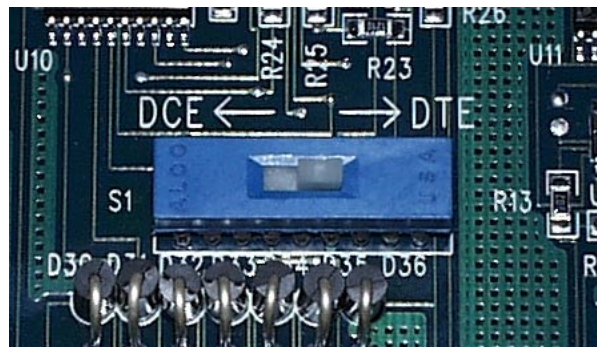

Figure 6. DCE VERSUS DTE SELECTOR SWITCH

The configuration software can also select the addresses to bridge across the MCS-11 ports. If any addresses have been specified for bridging, then MCS-11 polls and answers for those selected addresses, arriving at either MCS-11 port, are re-transmitted out the other MCS-11 port. The unit may also be configured to either send out its own answers (replies to polls) on both ports, or only on the port from which the poll was received. The typical setting for synchronous MCS-11 protocol

is to always send the answers to polls out both ports.

Special conditions may require that the 2310 AL send answers to polls for itself only out the receiving port. This might apply to a situation where the 2310 AL is part of a spur, with one port set for a high-speed synchronous connection to the backbone, and the other port set for a slow-speed asynchronous link to the spur radios. You may not want to incur the delay of sending answers to polls out the slow-speed downstream link, if the poll only comes in on the high-speed port. In this situation you would configure the unit to *not* send its answer out both ports, and to *only* bridge polls for the station addresses of any downstream spur radios across to the other port. This keeps the number of slow-speed packets to a minimum.

NOTE: Configuring a 2310 AL to *only* send its answer out on the port from which it was received, or to *block* certain MCS-11 station addresses from being bridged, does not strictly follow the MCS-11 protocol. Setting these options means that not all data packets would be visible if monitored at the far end of the radio hop or spur. There might be other equipment (such as multi-mastered polling engines, 5100 Test Sets, etc.) downstream from the 2310 AL that need to monitor all polls and answers, from all station addresses in the network. You would typically configure the 2310 AL to bridge all station addresses and send answers to polls out both ports in this situation.

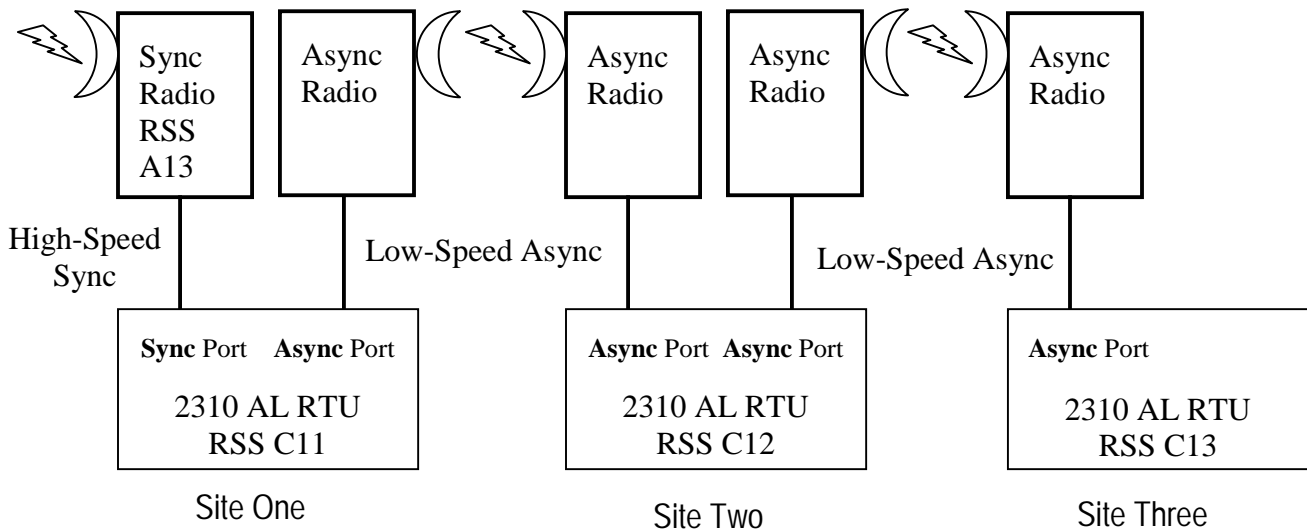

Figure 7. EXAMPLE OF HIGH-SPEED SYNCHRONOUS TO LOW-SPEED ASYNCHRONOUS SPUR

If you have a 2310 AL RTU configured to bridge through to a low-speed asynchronous spur (with nothing monitoring the system from the end of the spur), you could configure the 2310 AL to minimize the delays incurred by bridging unnecessary data packets through the low-speed spur section.

In the example in Figure 7, if the 2310 AL RTU at Site One (addressed as C11) were configured to *not* answer on both ports and to *block* all addresses except C12 and C13, then the only traffic across the low-speed asynchronous link would be the polls and answers for addresses C12 and C13. All other polls and answers would not be passed through the first 2310 AL and on to the spur.

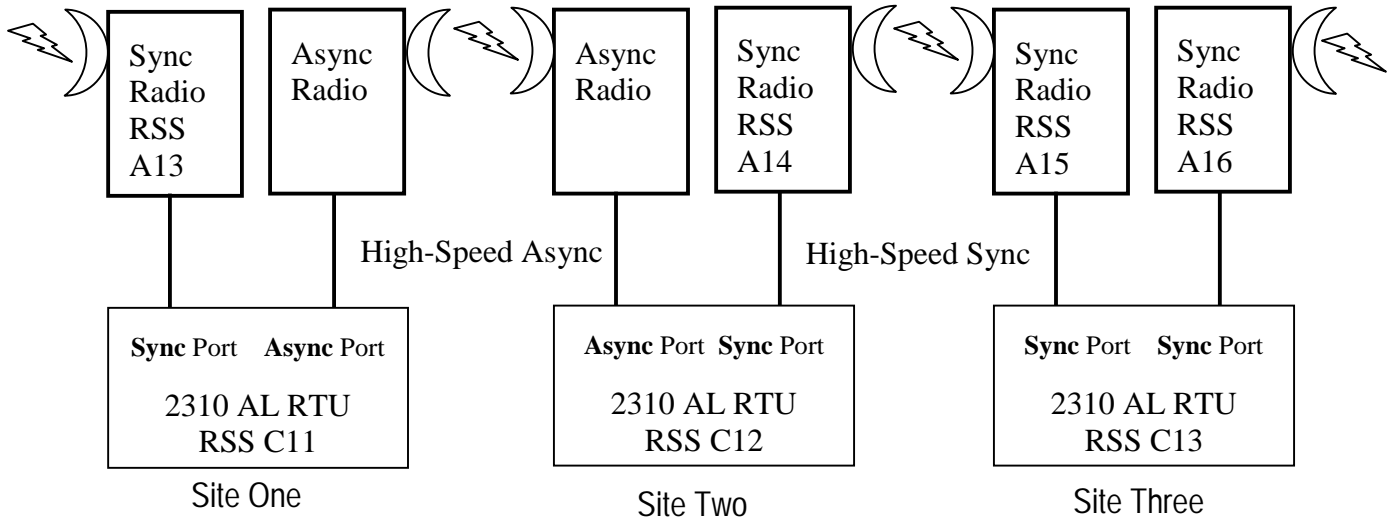

Figure 8. EXAMPLE OF HIGH-SPEED ASYNCHRONOUS HOP

In the example in Figure 8, two 2310 AL RTUs are used to provide an asynchronous link between a section of a high-speed synchronous radios. The speed of the asynchronous link depends only on the capabilities of the transport mechanism. The 2310 AL can support asynchronous speeds from 1200 to 19200 bps. Always use the highest asynchronous speed possible. Using speeds that are too low may require adjustments to timeout and poll response delay settings in other equipment on the network and may seriously affect system response. You would typically configure each 2310 AL to bridge all station addresses and send answers to polls out both ports in the above example.

For networks monitored by multiple masters (polling engines), 5100 Test Sets, or in a ring configuration, a slow-speed asynchronous hop may cause data packets to be lost unless Polling Engine parameters are set to accommodate the slower response times.

When using the 2310 AL for asynchronous hops across an MCS-11 synchronous network, or on a spur, you should adjust your AE-36S-X or 260X Polling Engine poll response time-out and interpoll delay settings. This is necessary to allow packets to finish transmission before the next packet arrives, and to allow for the added delay in getting responses back.

The table below offers suggested times to be *added* to the Polling Engine poll response time-out and interpoll delay settings for different asynchronous baud rates. Take the time from the table, multiply by each 2310 AL in the path configured for asynchronous communication, then add the total to the current Polling Engine poll response time-out and interpoll delay settings.

Baud Rate	Add to PE Poll Response Time-Out and Interpoll Delay
1200	320 ms
2400	160 ms
4800	80 ms
9600	40 ms
19200	20 ms

Table 3. ADDITIONAL TIMES FOR ASYNC HOPS

Two 15-pin DB-15 female connectors are used for the MCS-11 ports. If you are connecting to MCS-11 RS-422 equipment, the best type of cabling to use would be twisted pairs. The pairings for these MCS-11 ports are: Pin 1 with pin 9; pin 2 with pin 10; pin 3 with pin 11; pin 4 with pin 12; pin 5 with pin 13; and pin 6 with pin 14. Pin 15 is unused.

CRAFT INTERFACE: The craft interface port is for a temporary connection to a PC Com port. This port is used to download a new configuration to the unit, upload an existing configuration from the unit, or to monitor real-time alarm conditions for troubleshooting. The included Windows program performs all of these operations.

A single DB-9 female connector is used for the craft port interface. The pin assignments permit a direct connection to a 9-pin PC COM port. A straight-through connected cable with 9 wires will work, however only 3 wires are required. The cable will require a male DB-9 at the 2310 AL end, and (usually) a female DB-9 at the computer end. The pin assignments are detailed in Table 10 on page 30.

PROGRAMMING

An included Windows based program is used to configure the MCS-11 Encoder. The configuration data is transferred between the PC and the MCS-11 Encoder's craft port using COM 1, 2, 3, or 4. To install the software, simply copy the file named "FC2310.exe" from the supplied floppy disk to your hard disk, or run the program directly from the floppy disk.

Enter the appropriate configuration settings as described below. When you run this program, the following main screen appears:

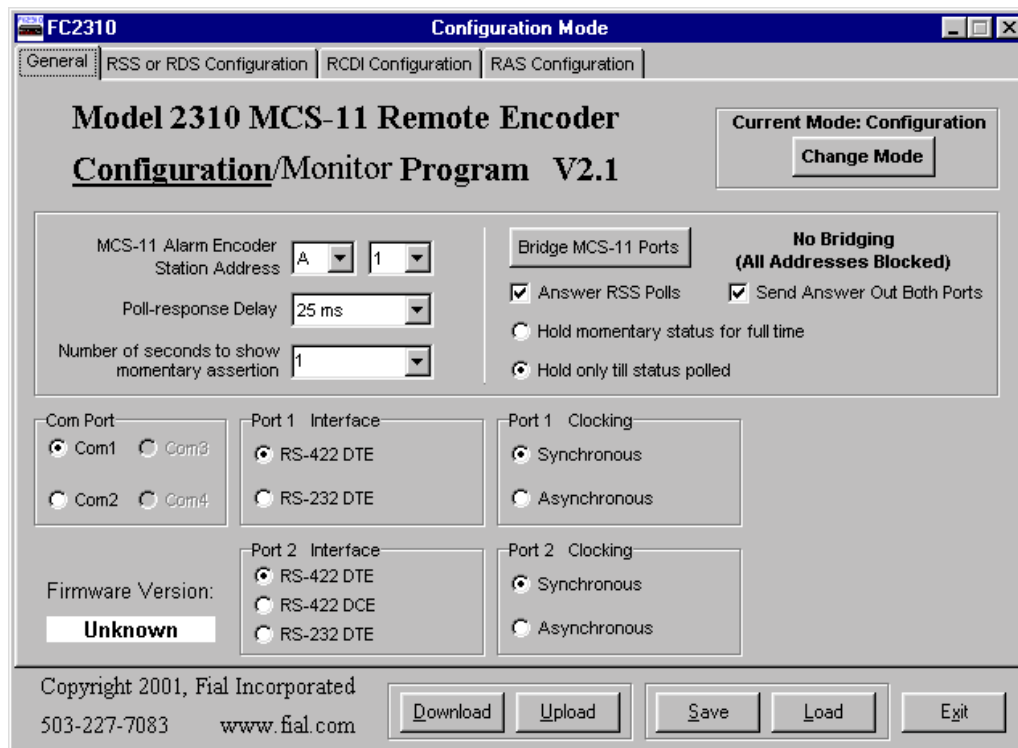

Figure 9. GENERAL PAGE (DEFAULT)

The program has a set of four tabs that you may use to select different views or 'pages'. The first page is called General, and is concerned with configuration settings that apply to the Model 2310 AL unit as a whole. The following sections explain each setting.

MCS-11 ALARM ENCODER STATION ADDRESS: The Station address desired for the 2310 AL must be set properly. The address range is *A* through *H* and *1* through *16* (128 possible addresses). Note: Address *H16* should *not* be used if you are planning to use multiple MCS-11 polling engines with poll synchronization.

BRIDGE MCS-11 PORTS: You must push the *Bridge MCS-11 Ports* button if you want MCS-11 polls and answers to be bridged (passed through) between MCS-11 ports one and two. The default condition is to block (not bridge) all addresses. Pressing the Bridge MCS-11 Ports button opens the Bridge Polls dialog window (see Figure 10).

This dialog window allows you to select some, or all, of the available MCS-11 addresses to bridge through the 2310 AL. Addresses in the left pane are blocked, and addresses in the right pane are bridged. Polls and answers received on one port for any bridged address are passed through to the other port. Highlight the desired addresses (using standard Windows techniques) and press the single arrowhead buttons to move the selected addresses from one pane to the other. Use the double arrowhead buttons to move ALL entries (highlighted or not) from one pane to the other. Press the OK button to accept the settings.

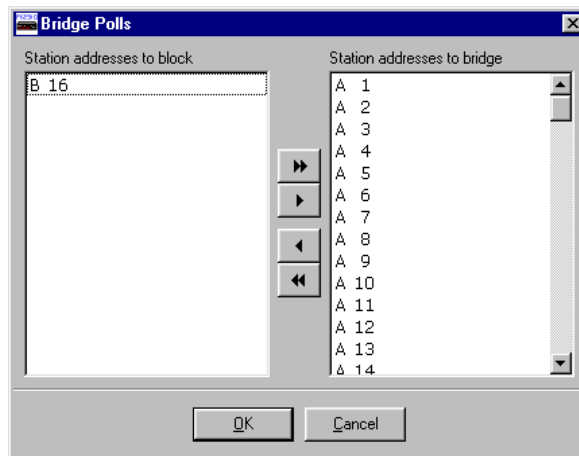

Figure 10. BRIDGE POLLS SELECTION

There is a status line immediately to the right of the *Bridge MCS-11 Ports* button that indicates the current bridging condition, see Figure 9. This line will read either 'No Bridging (All Addresses Blocked)', or 'Bridging (1 or More Addresses Bridged)'.

ANSWER RSS POLLS: This box must be checked if you want to respond to polls for the RSS of this unit's station address. If you have assigned alarms to an RDS and set an RSS summary point, then this box is automatically checked and grayed out. If you assign the unit alarm points to an RDS and do not select an RSS summary point, the Answer RSS Polls checkbox is automatically unchecked and grayed out. If the *Answer RSS Polls* box is not checked, then the unit will not answer polls for this station address RSS. This box would not be checked if you already have an RSS responding at the site using the same MCS-11 address as the 2310 AL, and are 'overlying' additional RDS scanners at that address. The summary relay contact may then be used to assert a summary bit in the pre-existing RSS. See appendix A if you are not checking this box.

SEND ANSWER OUT BOTH PORTS: This box must be checked if you want the 2310 AL to send its answers to polls out both MCS-11 ports. If you only want the unit to respond to polls for its address only on the same port on which the poll was received, then leave this box unchecked.

This option has nothing to do with the Bridge/Block option mentioned earlier. Even if you have the RSS address of the 2310 AL blocked (set to not be bridged), you can still set the unit to send its answers out of both MCS-11 ports with this option.

NUMBER OF SECONDS TO SHOW MOMENTARY ASSERTION: This entry field lets you specify the number of seconds that the RCDI status shows a momentary point to be ON after a momentary ON command. The relay will close for only 200 milliseconds, but you may wish the RCDI status for the relay to show the ON event for 30 seconds or more, such that an operator gets feedback of the ON event. This setting works in conjunction with the two radio buttons below.

HOLD MOMENTARY STATUS FOR FULL TIME: Any 2310 AL control point may be configured for momentary mode, where an MCS-11 ON command closes the associated relay for 200 milliseconds. This is too short a time for many MCS-11 masters to read the RCDI status and see that the relay actually operated. If you click on this radio button, the status of momentary control points will remain ON for the entire time set in the *Number Of Seconds To Show Momentary Assertion* box.

HOLD ONLY UNTIL STATUS POLLED: If you click on this radio button, then the control point ON status will be cleared after the first 'read' of the status scanner by the master. The status will be cleared even if the total number of seconds set in the *Number Of Seconds To Show Momentary Assertion* box has not yet passed. In that case, the MCS-11 master will see the control point status as ON for the first poll, then OFF with the next poll.

POLL-RESPONSE DELAY: This value should be set to 10 to 15 milliseconds for a typical MCS-11 system. This insures that MCS-11 equipment that bridge traffic have cleared and are ready for the response.

COM PORT: Choose the PC COM port which you will use to connect to the 2310 AL for download and upload of the configuration parameters, and to monitor real-time alarm events.

PORT 1 INTERFACE: Selects MCS-11 Port 1 physical protocol. Choose RS-422 or RS-232 operation. RS-232 is generally used only for connecting to synchronous modems. RS-422 is generally required or preferred for everything else.

PORT 1 CLOCKING: Selects MCS-11 Port 1 clocking. Choose from either Synchronous or Asynchronous modes. Typical MCS-11 systems use Synchronous clocking, where there are separate transmit and receive data and transmit and receive clock signals. Clock signals are provided by the DCE device.

Some special situations may require use of Asynchronous mode. Asynchronous mode only uses transmit and receive data signals. Separate transmit and receive clock signals are not used in asynchronous mode.

CHOOSE BAUD RATE OF PORT 1: Use this drop-down list box to select the MCS-11 Port 1 clock rate. This list box only appears when Asynchronous clocking mode is selected.

PORT 2 INTERFACE: Selects MCS-11 Port 2 physical protocol. Choose RS-422 or RS-232 operation. For RS-422 operation, you may choose either DTE (port accepts clock) or DCE (port generates and outputs clock) operation. If DCE is chosen, then a selection box appears which allows you to choose the clock rate. Set the DTE / DCE slide switch appropriately -- see Figure 6.

PORT 2 CLOCKING: Selects MCS-11 Port 2 clocking. Choose from either Synchronous or Asynchronous modes. Typical MCS-11 systems use Synchronous clocking, where there are separate transmit and receive data and transmit and receive clock signals. Clock signals are provided by the DCE device.

Some special situations may require use of Asynchronous mode, where the clock rate is set (the same) at both DTE and DCE devices. Separate transmit and receive clock signals are not used in asynchronous mode.

CHOOSE BAUD RATE OF PORT 2: Use this drop-down list box to select the MCS-11 Port 2 clock rate. This list box only appears for RS-422 DCE Synchronous mode, and for any Asynchronous clocking mode selection.

FIRMWARE VERSION: This area displays the 2310 AL firmware (internal software) version. This information is obtained from the unit before a download or upload session. Mismatched configuration software and unit firmware versions will not communicate properly. This display is for informational purposes.

DOWNLOAD BUTTON: This button downloads the current configuration *to* a 2310 AL device. If the cable to the craft port is not connected or the 2310 AL is not responding, a 'Port Time Out' message appears. The 2310 AL must be powered up, but it is not required to have connections to any ports other than the craft interface. A warning box appears to remind you to throw the internal DTE / DCE switch to the proper position, depending on the configuration setting chosen. Make sure to set the internal slide switch to either DTE or DCE to match the configuration program setting for the 2nd MCS-11 port. After a successful download, the 2310 AL automatically resets.

UPLOAD BUTTON: This button uploads the current configuration *from* a 2310 AL device. All settings in the Windows program are reset to match those of the 2310 AL. This option is useful if you do not have access to the saved configuration disk file for that unit.

SAVE AND LOAD BUTTONS: These buttons allow you to save a configuration to a disk drive and then to re-load the configuration later. It is recommended that all configurations be saved with a name that matches the station address used in that configuration. This allows configurations to be checked at a later time if there is doubt as to a setting. You may choose any file name you desire for these files, however a *.cfg* extension is automatically added.

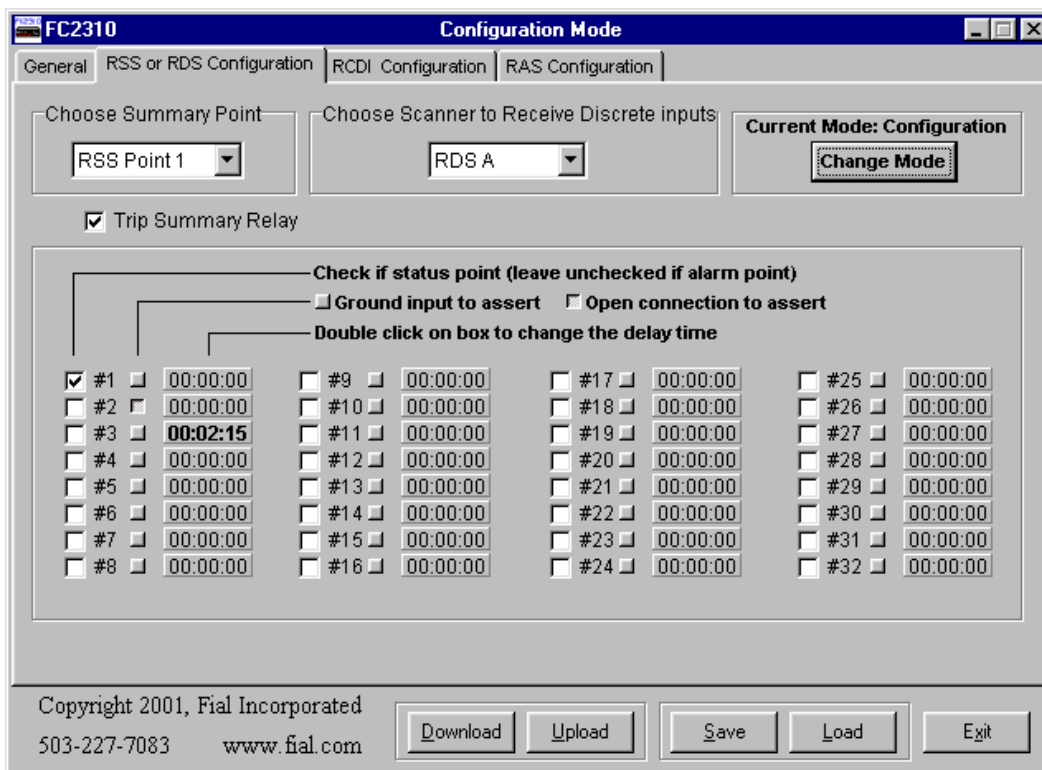

Figure 11. RSS OR RDS PAGE

The RSS or RDS Pane is used to specify which scanner will receive the alarm and status points, set up a summary bit in the RSS (for the RDS), specify for each point if it is an alarm point or a status point, and specify an optional delay for each point. You can also specify that the summary relay will be closed when there are one or more alarms asserted in the designated RSS or RDS.

CHOOSE SCANNER TO RECEIVE DISCRETE INPUTS: This drop-down list box is used to select the scanner used for the 32 alarm inputs. The choices are; the RSS scanner, or any one of the 15 possible RDS scanners (*A* through *R*). An RSS scanner contains 32 points. Each of the RDS scanners contain 72 points, only the first 32 points of which can be used. If the 32 inputs of the 2310 AL are placed into an RDS, then a 'Choose Summary Point' drop-down list box appears. You choose a summary point to assert in the associated RSS in order to trigger an automatic poll of the RDS.

It is possible to avoid using a 2310 AL RSS summary point by choosing 'No Summary Point'. In this case, the RDS must then be read by triggering an external RSS summary point with the Summary Relay. Check the 'Trip Summary Relay' box for this option. A less desirable possibility it to put the RDS in cyclic poll (this greatly slows down MCS-11 system polling).

CHOOSE SUMMARY POINT: Use this drop-down list box to select the desired RSS summary point to assert when any alarm point in the chosen RDS scanner becomes asserted (active). You may select No Summary Point if you do not want to assert an RSS summary point. This box is not

displayed unless an RDS scanner is chosen.

TRIP SUMMARY RELAY: Check this box if you want the summary relay to close whenever there is an alarm present on one or more of the inputs. The contacts of this relay can be used to operate a local alarm indicator, or to assert an RSS summary bit in an existing RSS at the site.

ALARM VS STATUS CHECKBOXES: The default is for these checkboxes to be blank, which means that the corresponding input is an alarm point. Points in alarm cause the designated RSS summary bit to be set when they are asserted at the input connector. They also cause the alarm event to be latched into the RSS or RDS scanner until it is 'seen' (polled) by the MCS-11 master.

If a box is checked, then the corresponding input is a status point. Status points do not cause the summary bit to be set when they are asserted at the input connector. Status points are not latched, and may be 'missed' by the MCS-11 master if it polls at the instant that the status point is unasserted. In Figure 11, point #1 is designated as a status point. All the others are alarm points.

GROUND INPUT TO ASSERT: Each point can have its input set for normal operation (ground the input to assert it) or inverted operation (disconnect from ground to assert the point). Click on the Ground Input To Assert buttons to toggle their states. For example, in Figure 11 only point #2 is set for inverted input. This means that point #2 is normally connected to ground for an unasserted condition and asserted (in alarm), when disconnected from ground. The other points in this scanner are asserted whenever they are connected to ground.

ALARM DELAY TIME: Each point can have a delay time set, which prevents the input event from being reported to the Master unless the input is asserted continuously for longer than the delay time. This is useful for alarms that are not critical if they are ON for a short period of time (such as a fan), but are serious if they remain ON.

The delay value for each point may be set with one second resolution up to 18 hours. In Figure 11, point 3 has a delay setting of 2 minutes and 15 seconds. Therefore, an input for point number 3 must be asserted continuously for 2 minutes and 15 seconds before the point will be set in the RDS scanner and reported to the Master. The event will not be reported at all if the point is only asserted for a period less than 2 minutes and 15 seconds.

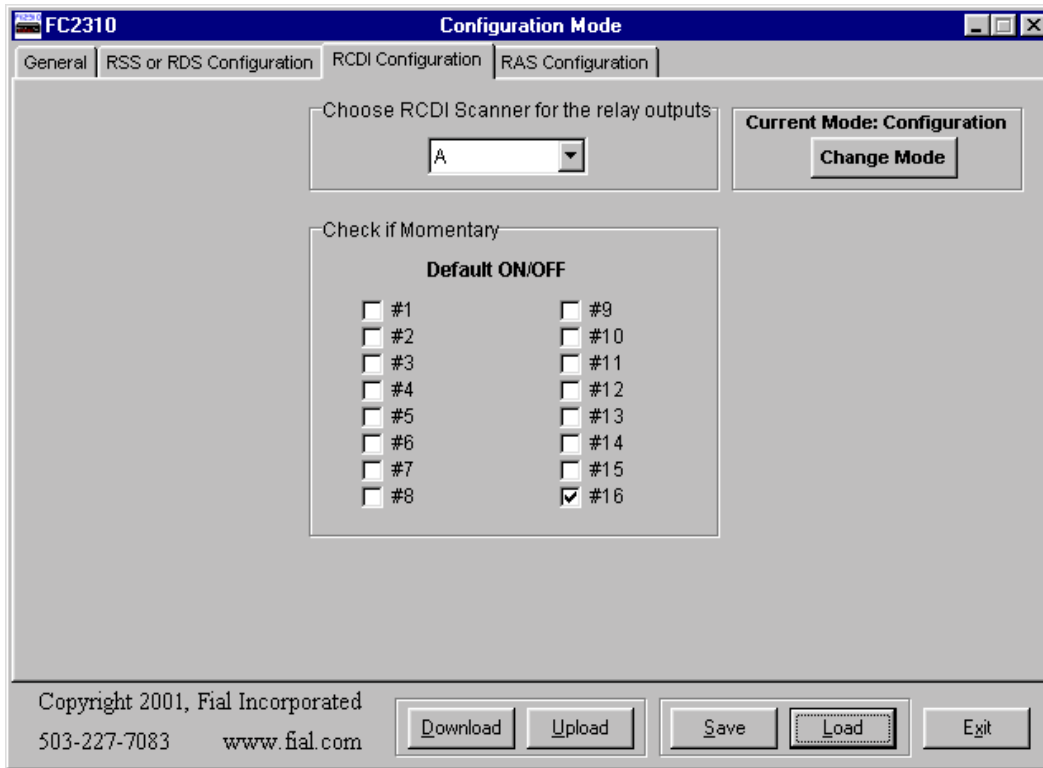

Figure 12. RCDI PAGE

The RCDI pane is used to specify which RCDI scanner will operate the 16 relays. A checkbox for each relay allows ON/OFF or Momentary operation. This is discussed in detail below.

CHOOSE RCDI SCANNER FOR THE RELAY OUTPUTS: You are allowed to select a RCDI scanner from *A* through *F*. All 16 control points in the 2310 AL will be controlled via the scanner which you select.

CHECK IF MOMENTARY: The control points default to the ON/OFF mode. An MCS-11 *ON* command will *close* the targeted relay. An MCS-11 *OFF* command will *open* the targeted relay.

If the checkbox next to the control point number is checked, then that point will be configured for momentary mode. In momentary mode, an ON command causes the relay to be closed for 200 milliseconds, then released. An OFF command is ignored. When momentary points are actuated, the MCS-11 RCDI status reflects the ON condition to the master. The amount of time that a momentary point's status is reflected as ON must be set in the configuration program. See the item *Number Of Seconds To Show Momentary Assertion* under the General tab on page 15.

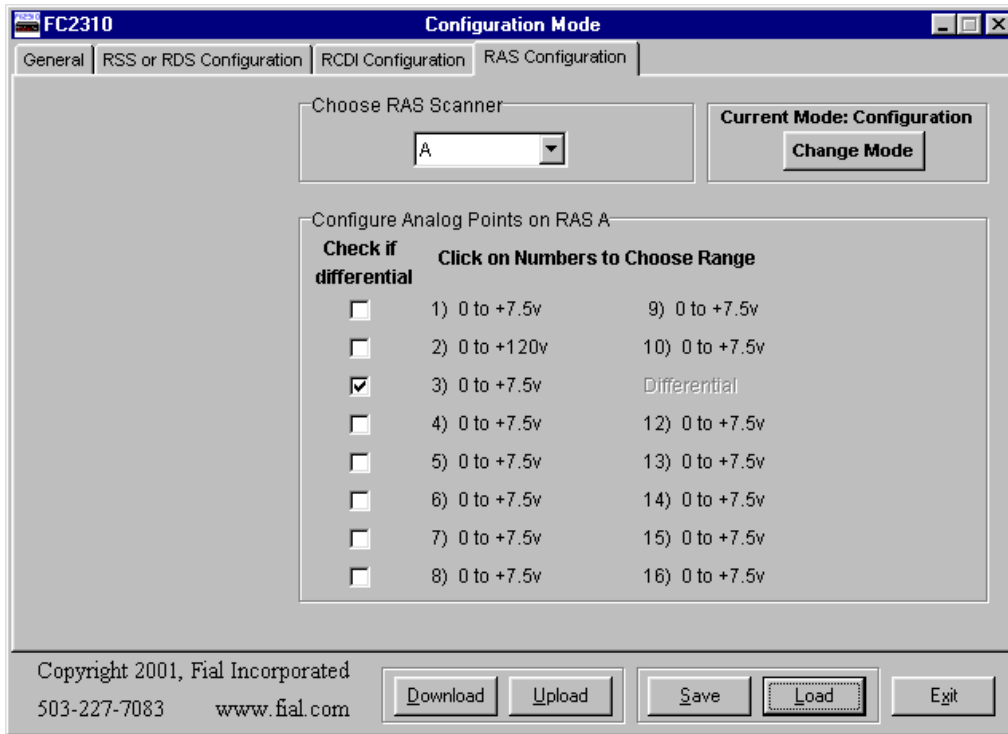

Figure 13. RAS PAGE

The RAS pane allows you to specify which RAS scanner will receive the analog values. An RAS scanner can contain 24 values, but only the first 16 values will be used by the Model 2310 AL. The number of values will be less than 16 if some analog inputs are used in differential mode. If input #1 is used in differential mode (input pair formed by inputs #1 and #9), then the analog value will be placed in the 1st position, and nothing (just the grayed-out word 'Differential') will be placed in the 9th position. If all the inputs are used in differential mode, then the values will be placed in positions 1 through 8, and no values will be placed in positions 9 through 16.

CHOOSE RAS SCANNER: One of the 12 valid RAS scanner addresses must be chosen for proper operation. You cannot configure the analog points until a scanner address is selected. You can change the scanner address (e.g. from B to C) without affecting your range selections. However, if you select NONE as the scanner address, then all point ranges are reset to the plus (+) 7.5 volt range.

Selecting an analog scanner address without having installed the optional analog-input board is an error condition. Downloading this configuration to a 2310 AL causes the front panel Unit Fail LED to blink three times, pause, then repeat, to indicate the error.

CHECK IF DIFFERENTIAL CHECKBOXES: The default is for all boxes to be unchecked, which allows for 16 separate voltage measurement inputs. If a box is checked, then the corresponding input to the right of the checkbox is configured as a differential input. In Figure 13, input number 3 is checked. This means that input 3 and 11 will be a configured as a differential input pair. Notice the grayed-out word 'Differential' replaces the input number and voltage range for input 11.

CHANGE VOLTAGE RANGES: To change the voltage range of an input, click on the desired analog point number (1..16) to the right of the checkboxes. When you click on any one of these 16 inputs (e.g. input **2, 0 to +120v**), a box appears allowing you to select the voltage range for that input. There are 15 ranges shown, but only the first 10 are used (see note below). The possible ranges are from 7.5 volts to 120 volts. Each input or differential pair may be set to measure a range of positive voltages, or a range of negative voltages.

Note: MCS-11 masters do not currently support the bipolar ranges, so those ranges should not be selected. If bipolar is selected for an input, the generated RAS values are as follows: The negative limit is set at 000, the zero potential is 499, and the positive limit is set at 999. For example, choosing +/- 15 Volts will cause the RAS to report minus 15 volts as 000, zero volts as 499, and plus 15 volts as 999.

REAL TIME MONITORING

The 2310 AL can be set to monitor and display its alarm input conditions, the status of its control outputs, and its analog input values. This can aid in field troubleshooting and verify that the 2310 AL is functioning properly.

To start Monitor mode, first select the appropriate COM port (used to communicate with the 2310 AL craft port), then press the *Change Mode* button found on all four of the tabbed pages. The current mode, either Configuration or Monitor, is always displayed above the button. The program immediately uploads the current configuration data from the 2310 AL, then switches to Monitor mode. All configuration functions are disabled in Monitor mode, but you can select any of the tabbed pages to display the desired RSS or RDS alarm points, RCDI control point statuses, or the RAS analog input values.

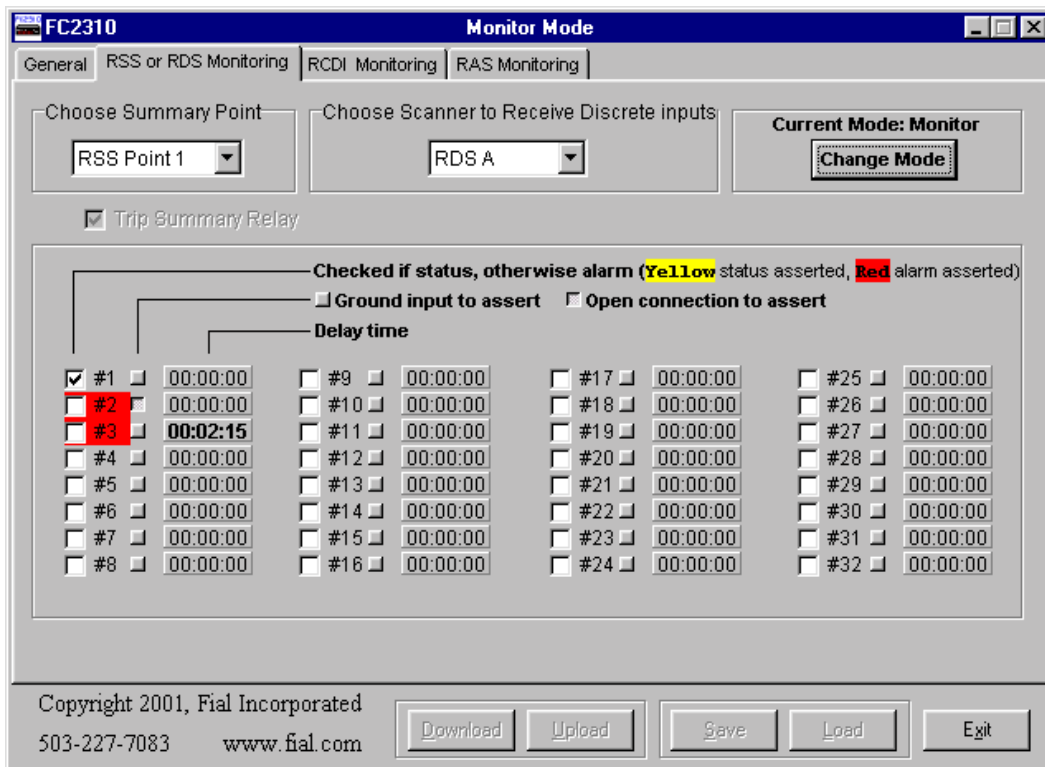

Figure 14. RDS PAGE IN MONITOR MODE

The input readings are refreshed automatically every 1 to 2 seconds and are images of the appropriate scanners (RSS or RDS, RCDI, & RAS). If an RSS or RDS alarm input is set for a delay, the input must remain asserted for the complete delay time before it is shown as asserted on the Monitor page. Asserted alarm points are highlighted in red, status points in yellow.

Press the Change Mode button again to return to Configuration mode.

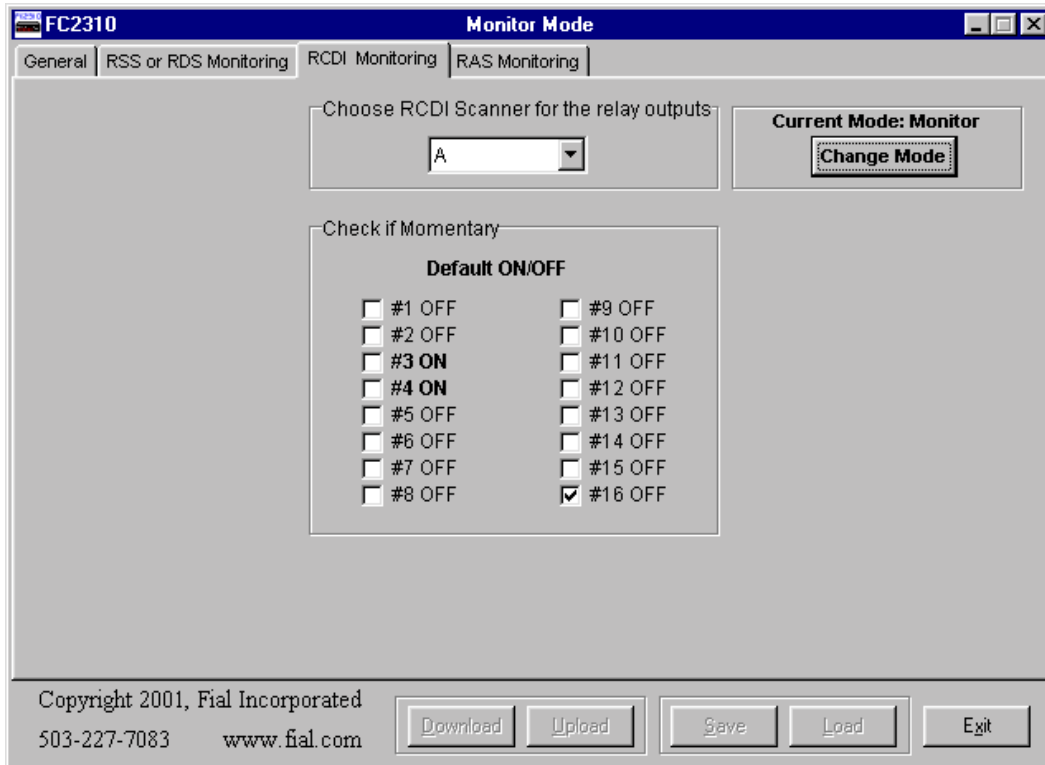

Figure 15. RCDI PAGE IN MONITOR MODE

Notice that control points that are current ON are also in **bold** print. Because the image is refreshed approximately once a second, asserted momentary controls may not be displayed properly if the *Number Of Seconds To Show Momentary Assertion* is set too short, or the *Hold Only Until Status Polled* radio button is selected.

Press the Change Mode button again to return to Configuration mode.

MODEL 2310 AL MCS-11 REMOTE ENCODER

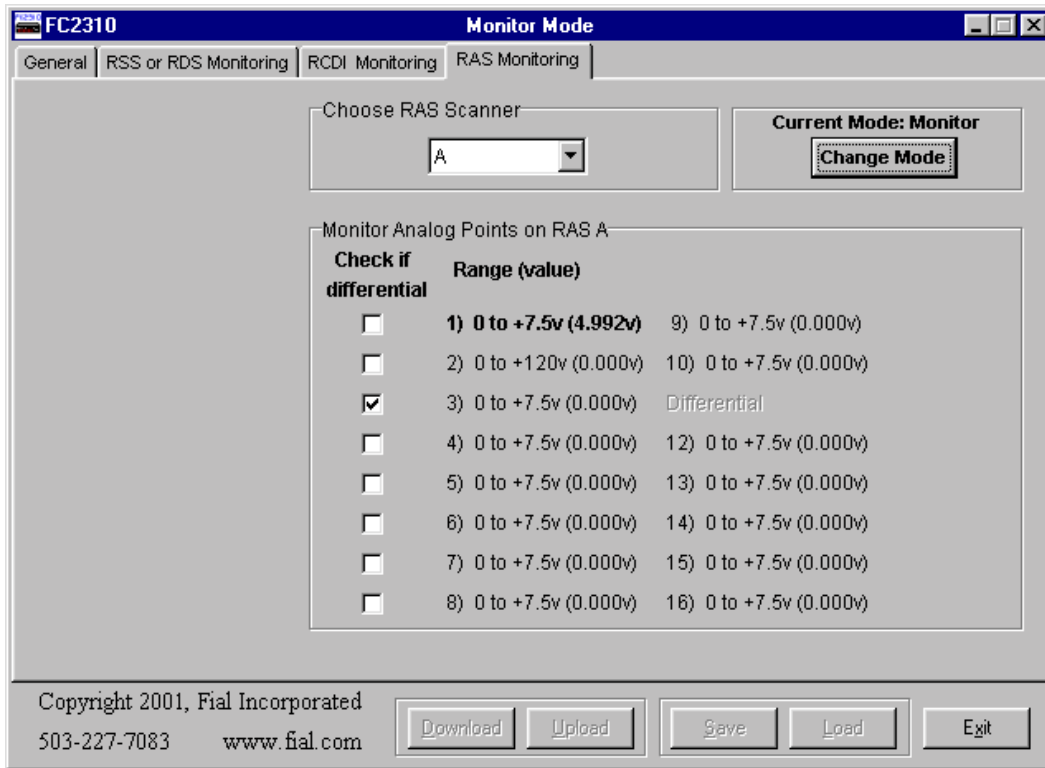

Figure 16. RAS PAGE IN MONITOR MODE

Analog values that are above or below zero volts are displayed in **bold** print.

Press the Change Mode button again to return to Configuration mode.

MCS-11 REMOTE ENCODER MODEL 2310 AL SPECIFICATIONS

PHYSICAL

height: 1 and 23/32 in. (1U)

width: 19 in.

depth: 11 in.

weight: 5.2 lbs.

POWER REQUIREMENTS

supply voltage: 18 volts to 56 volts, positive or negative ground

supply current: 215 ma @18 volts, no relays activated, no analog option card

475 ma @18 volts, all relays activated, no analog option card

305 ma @18 volts, no relays activated, with analog card installed

570 ma @18 volts, all relays activated, with analog card installed

(note: current draw decreases as voltage increases)

supply fuse: internal 1 Amp 250 Volt 2AG fuse

connections: barrier terminal strip - rear panel

RELAY OUTPUTS

connections: Form-C contacts for all 16 relays are available on a 50-pin female ribbon connector on the rear panel. Each relay's common connection is internally fused (1 Amp. pico fuse). An additional Form-A relay output is available to set an external RSS summary point.

current rating: 1 Amp maximum in 24 or 48 volt station service, 0.6 Amp in 120 Volt service

OPTO ISOLATED INPUTS

connections: The 32 inputs are available on a 50-pin female ribbon connector on the rear panel.

input load: 22K Ohm pull-up to station battery (monitored equipment must sink 2ma maximum to station ground in order to assert alarm). Bi-directional LEDs are used in the optoisolators, so positive or negative ground systems both work properly.

ANALOG INPUTS (OPTIONAL)

connections: The 16 inputs are available on a DB-25 female connector on the rear panel.

input load: 52K Ohms input resistance to ground for all inputs.

MCS-11 CONNECTORS

There are two MCS-11 DB-15 female connectors (Two MCS-11 ports). Each port is DTE (accepts clock) and can be configured for RS-422 or RS-232. The second port can also be configured for DCE (outputs clock) and set to a user specified baud rate.

RS-422 SIGNALS:

- Idle condition: + data line (the A-lead) is more negative than the - data line (the B-lead) during the inter-packet interval.
- Clock phase: Data changes on positive going edge of the + clock. Data is stable on the negative going edge of the + clock.
- For DTE, the following are outputs from 2310 AL: Return Clock, Transmit Data and Off Hook. DTE inputs are Receive Clock, Receive Data, and Transmit Clock.
- For DCE, the following are outputs from the 2310 AL: Receive Clock, Receive Data and Transmit Clock. DCE inputs are Return Clock, Transmit Data and Off Hook. Only port 2 can be set to RS-422 DCE.

MCS-11 ports input termination:

121 Ohms differential:

(+ data input biased to + 5 with 1K)

(- data input biased to gnd. with 1K)

FRONT PANEL INDICATORS

one green power indicator

one red unit-fail indicator

one red RSS alarm indicator

MCS-11 port 1 (green LEDs): TX clock, TX data, RX clock, RX data

MCS-11 port 2 (green LEDs): TX clock, TX data, RX clock, RX data

thirty-two green alarm point indicators (16 of which are also used for control relay status indication)

ENVIRONMENTAL

operating temp: 0 to 70 degrees C.

humidity range: 5% to 95% R.H. non condensing

MOUNTING

The MCS-11 Encoder mounts in a standard 19 inch rack. Mounting ears provide for a 5 1/8 inch projection out from the mounting surface. The mounting ears may be relocated to threaded holes near the front for flush mounting or 2 inch projection mounting.

MCS-11 REMOTE ENCODER CONNECTOR PIN ASSIGNMENTS

MCS-11 RS-422 CONNECTIONS:

Signal Name	Pin # (+ lead)	Pin # (- lead)
Receive Clock	1	9
Receive Data	2	10
Transmit Clock	3	11
Return Clock	4	12
Transmit Data	5	13
Off Hook	6	14

Table 4. MCS-11 RS-422 PIN ASSIGNMENT (DB-15F)

MCS-11 RS-232 CONNECTIONS (SYNCHRONOUS):

Signal	Pin #
Receive Clock	1
Transmit Clock	3
Return Clock	4
Transmit Data	5
Off Hook	6
Receive Data	7
DTR	15
Signal Ground	8

Table 5. MCS-11 RS-232 PIN ASSIGNMENT (DB-15F)

MCS-11 RS-232 CONNECTIONS (ASYNCHRONOUS):

Signal	Pin #
Transmit Data	5
Receive Data	7
Signal Ground	8

Table 6. MCS-11 RS-232 PIN ASSIGNMENT (DB-15F)

CONTROL (RELAY OUTPUTS) CONNECTOR: 50-PIN CENTRONICS/CHAMP TYPE

CAUTION: The relay output connector pin assignments do **NOT** follow typical Telco pin pairing.

Table 7. RELAY OUTPUT CONNECTOR PIN ASSIGNMENTS

Connection	Pin #
Relay 1 N.O.	1
Relay 1 Common	2
Relay 1 N.C.	3
Relay 2 N.O.	4
Relay 2 Common	5
Relay 2 N.C.	6
Relay 3 N.O.	7
Relay 3 Common	8
Relay 3 N.C.	9
Relay 4 N.O.	10
Relay 4 Common	11
Relay 4 N.C.	12
Relay 5 N.O.	13
Relay 5 Common	14
Relay 5 N.C.	15
Relay 6 N.O.	16
Relay 6 Common	17
Relay 6 N.C.	18
Relay 7 N.O.	19
Relay 7 Common	20
Relay 7 N.C.	21
Relay 8 N.O.	22
Relay 8 Common	23
Relay 8 N.C.	24
Relay 9 N.O.	25

Connection	Pin #
Relay 9 Common	26
Relay 9 N.C.	27
Relay 10 N.O.	28
Relay 10 Common	29
Relay 10 N.C.	30
Relay 11 N.O.	31
Relay 11 Common	32
Relay 11 N.C.	33
Relay 12 N.O.	34
Relay 12 Common	35
Relay 12 N.C.	36
Relay 13 N.O.	37
Relay 13 Common	38
Relay 13 N.C.	39
Relay 14 N.O.	40
Relay 14 Common	41
Relay 14 N.C.	42
Relay 15 N.O.	43
Relay 15 Common	44
Relay 15 N.C.	45
Relay 16 N.O.	46
Relay 16 Common	47
Relay 16 N.C.	48
Summary Relay N.O.	49
Summary Relay Common	50

ALARMS (OPTOINPUTS) CONNECTOR: 50-PIN CENTRONICS/CHAMP TYPE

CAUTION: The alarm input connector pin assignments do **NOT** follow typical Telco pin pairing.

Table 8. ALARM INPUT CONNECTOR PIN ASSIGNMENTS

Connection	Pin #	Connection	Pin #
Input #1	1	Input #26	26
Input #2	2	Input #27	27
Input #3	3	Input #28	28
Input #4	4	Input #29	29
Input #5	5	Input #30	30
Input #6	6	Input #31	31
Input #7	7	Input #32	32
Input #8	8	Station ground	33
Input #9	9	Station ground	34
Input #10	10	Station ground	35
Input #11	11	Station ground	36
Input #12	12	Station ground	37
Input #13	13	Station ground	38
Input #14	14	Station ground	39
Input #15	15	Station ground	40
Input #16	16	Station ground	41
Input #17	17	Station ground	42
Input #18	18	Station ground	43
Input #19	19	Station ground	44
Input #20	20	*Future option	45
Input #21	21	*Future option	46
Input #22	22	*Future option	47
Input #23	23	*Future option	48
Input #24	24	*Future option	49
Input #25	25	*Future option	50

ANALOG INPUT CONNECTOR (OPTIONAL FEATURE) (DB-25F)

Signal Name	DB-25 pin #	Signal Name	DB-25 pin #
Analog Gnd	pin 1	Analog Gnd	pin 14
Input #1	pin 2	Input #9	pin 15
Input #2	pin 3	Input #10	pin 16
Input #3	pin 4	Input #11	pin 17
Input #4	pin 5	Input #12	pin 18
Input #5	pin 6	Input #13	pin 19
Input #6	pin 7	Input #14	pin 20
Input #7	pin 8	Input #15	pin 21
Input #8	pin 9	Input #16	pin 22
Analog Gnd	pin 10	Analog Gnd	pin 23
*future option	pin 11	* future option	pin 24
Station Gnd	pin 12	* future option	pin 25
Station Gnd	pin 13		

Table 9. ANALOG INPUT CONNECTOR PIN ASSIGNMENTS

CRAFT INTERFACE CONNECTOR (DB-9F)

Signal Name	Pin #
Common	5
Data out from 2310 AL to PC	2
Data in from PC to 2310 AL	3

Table 10. CRAFT INTERFACE PORT (RS-232) PIN ASSIGNMENTS

APPENDIX A -- CONSIDERATIONS FOR TSM-2500/8000 CONFIGURATION

FOR SITUATIONS WHERE THE MODEL 2310 AL IS ANSWERING RSS POLLS FOR ITS OWN STATION ADDRESS:

The TSM alarm master should have the alarms mapped to an RDS, and a summary bit specified for the RSS. The MCS-11 master should poll the RSS, and do a secondary poll of the RDS when the specified summary bit is asserted. Note that it is possible to put all the 32 alarm inputs into the RSS, however there will then be no distinction between alarm points and status points. Any change in a status point will soon be 'seen' by the MCS-11 master and logged.

The master must have the RSS or RDS created at the address of the 2310 AL. A point name should be assigned to each of the 32 alarm input points in the 2310 AL.

The controls should be mapped to an RCDI. The equipment which is being controlled will generally determine if the control point(s) should be ON/OFF or momentary. The master should be configured so that it knows that the RCDI exists, and a name assigned to each control point.

If the analog card is used, then the master must have an RAS created at the address of the RAS in the 2310 AL. A point name must be assigned to each of the 16 input values. If any of the points in the range from 1 to 8 are differential inputs, then there will be less than 16 input values. Each point must be configured with a multiplier value (scaled), to cause the 000 to 999 RAS values to be displayed properly in volts, or whatever units the value represents. The multiplier value depends on the range and polarity of the analog input.

Each analog point has a high and low limit value specified. The default is a low limit of 000, and a high limit of 999. Set these upper and lower limits to some other scaled value, and if the value of the point strays outside this range, then the TSM master will log the event as an alarm.

The master should be set to the proper period (each 15 minutes, each hour etc.) to poll the analog scanners.

FOR SITUATIONS WHERE THE RSS IS EXTERNAL TO THE 2310 AL, PERHAPS IN AN EXISTING MICROWAVE RADIO, AND THE 2310 AL ONLY ANSWERS TO RDS, RCDI AND RAS POLLS:

In this case, it is desired to use the existing RSS in the radio with the 2310 AL supplying additional scanners to it. The 2310 AL alarms should be mapped to an RDS, 'No Summary Point' should be selected, and the 2310 AL's **summary relay** should be set to operate whenever an alarm point is asserted. The summary relay contacts should be wired to a station alarm input on the microwave radio, such that the relay can assert an unused bit in the radio's RSS when the relay is closed. This bit is designated the 'summary' bit for the RDS in the TSM alarm system.

The RDS must be mapped to a letter (D,E,F, etc.) that is not answered by the MCS-11 equipment in the radio. If this is not possible, then the RDS may be put in cyclic poll in the master, however this is

MODEL 2310 AL MCS-11 REMOTE ENCODER

not recommended, except in an emergency situation. The MCS-11 polling process will be slowed down substantially if many RDSs are put in cyclic poll.

FOR SITUATIONS WHERE THE MODEL 2310 IS CONFIGURED WITH A MODEL 260 ANALOG MODULE AND USED WITH THE TSM-2500 ALARM MONITOR PROGRAM:

The Model 2310 MCS-11 Remote Encoder without an Analog Module will work with all earlier versions of the TSM-2500 software. The 260 Analog Module requires different scaling factors and more precision than supported by the earlier versions of the TSM software. **Version 2.4** (or later) of the TSM-2500 supports the new Analog Module for the 2310. For proper operation with the analog module, make sure your TSM-2500 software is current.

The TSM-2532 and TSM-8000 alarm monitoring systems provide the proper scaling factors for the Model 260 Analog Module.

Please contact Tech Support Alcatel USA (888-252-2832) for TSM-2500 upgrade information.